

ORIGINAL GRIPPER®

Cherne's Gripper plugs can be used in a variety of applications including DWV (drain, waste and vent) testing and stack testing. End-of-Pipe design won't fall in, whereas the Inside-of-Pipe design allows you to locate the plug inside the pipe as far as you need. Time tested, the Gripper® remains one of the most popular mechanical plugs on the market.

Original Gripper® Plug Features:

- Ideal for sewer testing and long-term applications
- Made with glass-reinforced ABS plastic
- End-of-pipe design seals only at the end of a pipe
- Inside-of-pipe design seals inside pipe as far as needed

Equipped with:

- Easy-to-install extra large zinc wing nut – won't rust
- Natural rubber O-ring
- Galvanized carriage bolt to prevent corrosion

END-OF-PIPE GRIPPER



PART NUMBER	NOMINAL SIZE	USAGE RANGE	MAXIMUM BACK PRESSURE		LENGTH	PRODUCT WEIGHT
270210	1 1/2" (40 mm)	1.48"–1.65" (39–42 mm)	17 psi (1,2 bar)	40 ft. (12 M)	1.75" (44.5 mm)	0.13 lbs (0.05 kg)
270229	2" (50 mm)	1.9"–2.17" (49–55 mm)	17 psi (1,2 bar)	40 ft. (12 M)	1.87" (47.5 mm)	0.19 lbs (0.09 kg)
270237	3" (75 mm)	2.8"–3.1" (71–79 mm)	17 psi (1,2 bar)	40 ft. (12 M)	2.5" (63.5 mm)	0.375 lbs (0.16 kg)
270245	4" (100 mm)	3.8"–4.06" (96–103 mm)	17 psi (1,2 bar)	40 ft. (12 M)	2.5" (63.5 mm)	0.5 lbs (0.23 kg)
270261	6" (150 mm)	5.77"–6.08" (147–154 mm)	17 psi (1,2 bar)	40 ft. (12 M)	3.75" (95.3 mm)	2.5 lbs (1.14 kg)
270270	8" (200 mm)	7.7"–8.03" (196–204 mm)	17 psi (1,2 bar)	40 ft. (12 M)	3.75" (95.3 mm)	3 lbs (1.37 kg)

INSIDE-OF-PIPE GRIPPER

PART NUMBER	NOMINAL SIZE	USAGE RANGE	MAXIMUM BACK PRESSURE		LENGTH	PRODUCT WEIGHT
270296	4" (100 mm)	3.8"–4.06" (96–103 mm)	17 psi (1,2 bar)	40 ft. (12 M)	2.5" (63.5 mm)	.5 lbs (0.23 kg)
270253	6" (150 mm)	5.77"–6.08" (147–154 mm)	17 psi (1,2 bar)	40 ft. (12 M)	3.75" (95.3 mm)	2.5 lbs (1.14 kg)
270288	8" (200 mm)	7.7"–8.03" (196–204 mm)	17 psi (1,2 bar)	40 ft. (12 M)	3.75" (95.3 mm)	3 lbs (1.37 kg)

End-of-Pipe Gripper® plug

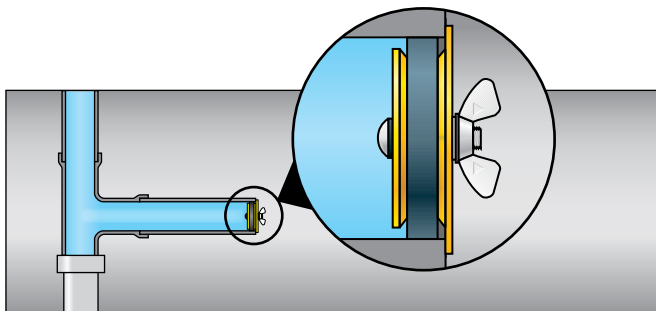

Inside-of-Pipe Gripper® plug

